

Cooling Pipes design and production status

M. Benettoni - 0312

- ?? Order issued to Cinel (~15kE, for MB1,2,3) beginning November (apart 2 flexible connections on all MB1 and a half of MB2 and MB3).
- ?? Pipes sent to the company in November, arrived mid November.
- ?? Drawings for pre-production given to the company 21st November
- ?? Pre-production (MB3 type) will be delivered to LNL tomorrow Dec.10th
- ?? Production expected to be very fast (according to producer)

Drawing status:

- ?? Some modifications needing discovered during chambers dressing
- ?? One mistake found in the models
- ?? Some missing information to Boki: e.g. 2 types of RPC (MB1) manifold

Due to those problems Boki has just finished to work on MB1,2,3. Hopefully he will be able to produce all the models – just models – for MB4 (enough for offers, order and production, but...) by end of the Year (03).

Carters and cable trays status

- ?? All the theta stuff produced
- ?? Problem with MB3- cable tray, interference with (big) excess of glue
- ?? A modified drawing has been made and order issued
- ?? Delivery expected by mid-end January

- ?? Front covers design “almost” finished, difficulties due to:
 - interferences between fixing block and FE covers screws,
 - cables and optic from MC
 - interferences with steel pipes
 - crowded area of manifold, HV cables, steel pipes

Split Board status

- ?? ~25mm thick body in front the MC, just at the right of the server board, supports manifold-like, requires some mechanics still to be designed.

SEZ. A-A

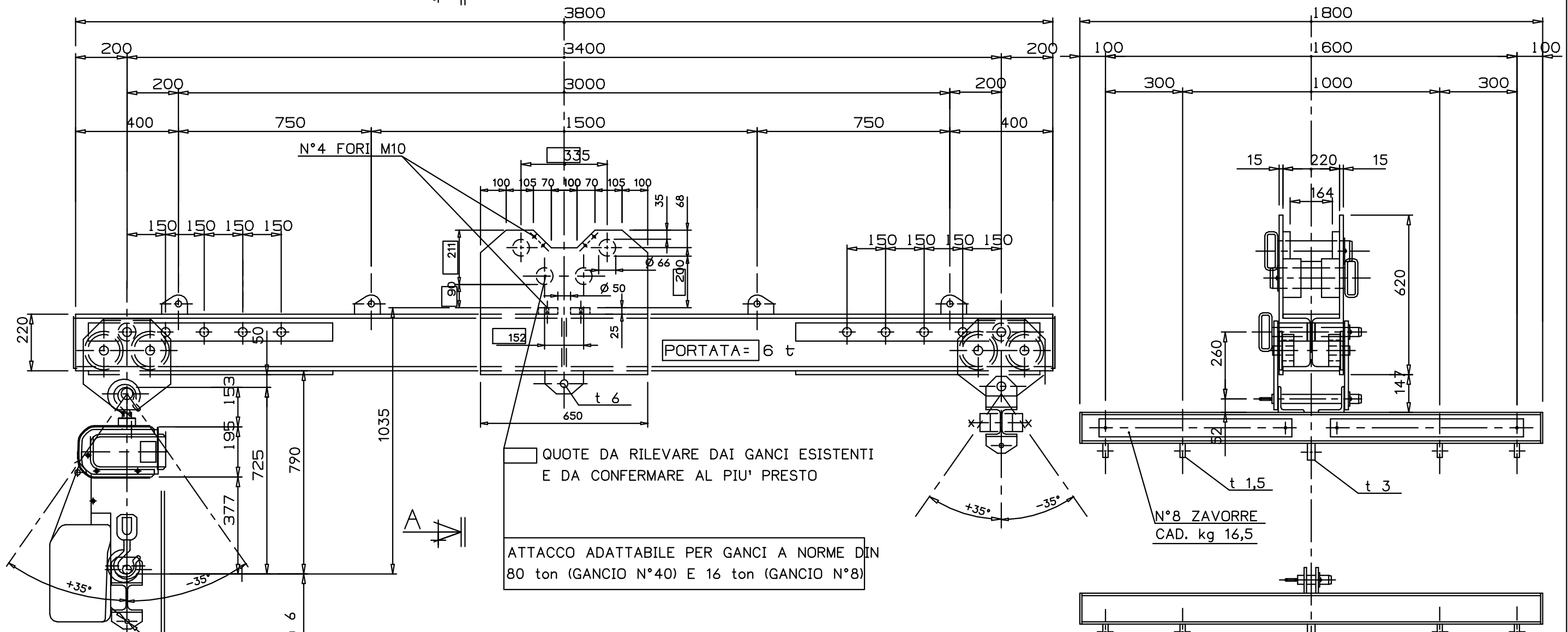

QUOTE DA RILEVARE DAI GANCI ESISTENTI
E DA CONFERMARE AL PIU' PRESTO

ATTACCO ADATTABILE PER GANCI A NORME DIN
80 ton (GANCIO N°40) E 16 ton (GANCIO N°8)

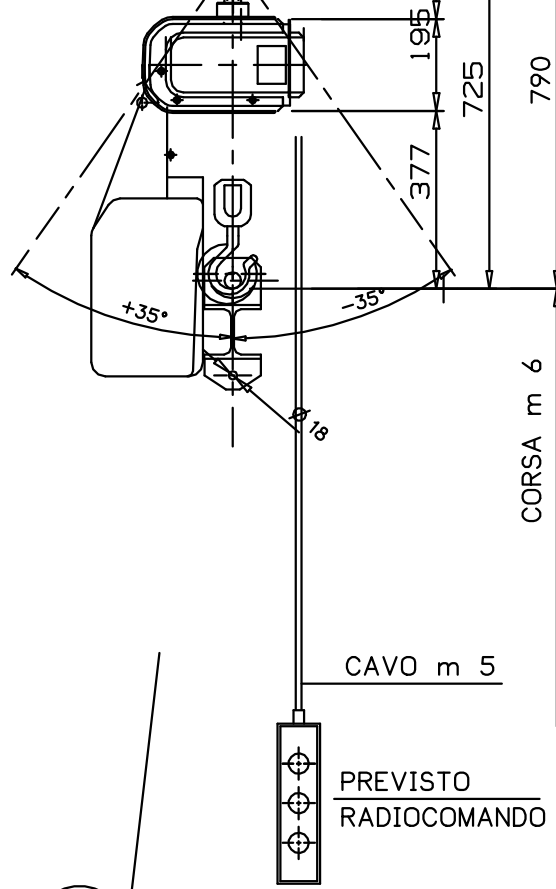

TAMBURO AVVOLGICAVO
CAVO LUNGH. m 20

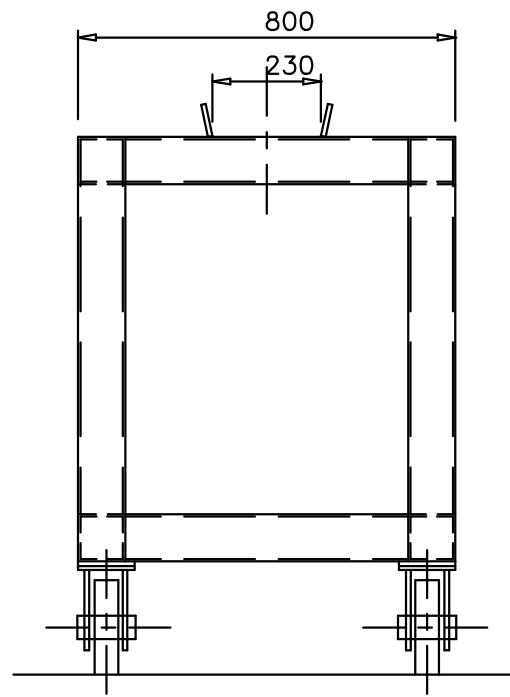
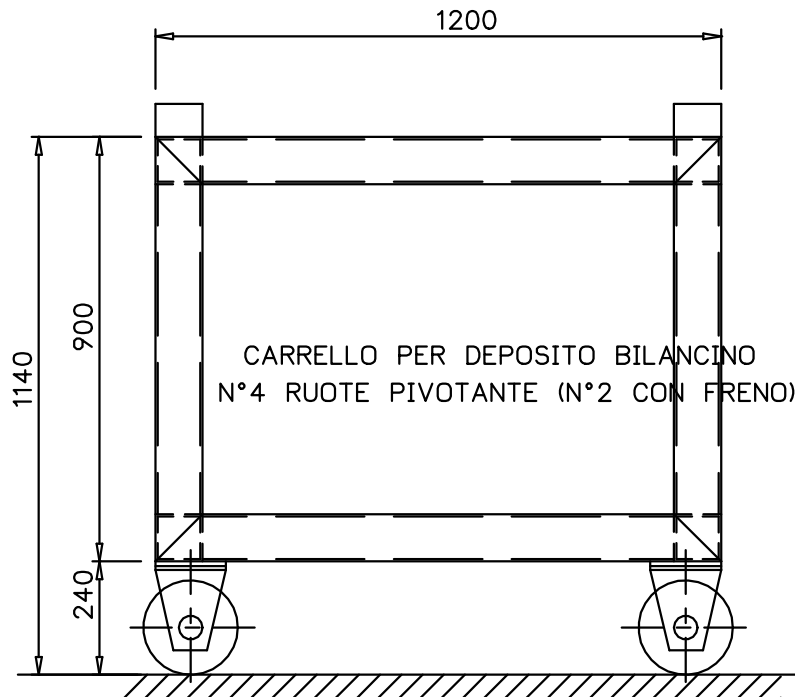

CICLO STANDARD COLORE
FINALE GIALLO RAL 1006

 20020 ARESE (MI) via Industrie 11/16 Tel.93583314-Fax93583316	TRAVESSA SPECI PORTATA= 6000	DISEGNATO D.Cogliati CONTROLLATO
		DATA 04 Dicembre 2003
		AGGIORNAM
		DIS. N°23054-A REV. 0

N.B. A TERMINI DI LEGGE CI RISERVIAMO LA PROPRIETA' DI QUESTO DISEGNO CON DIVIETO DI RIPRODURLO
E DI RENDERSI COME NOTO A TERZI SENZA NOSTRA AUTORIZZAZIONE.